

# A Soil Moisture Control System for Greenhouse Plant Stress Studies

F. D. McBride and George Rink

*Forestry research technician and research geneticist, USDA Forest Service, North Central Forest Experiment Station, Forest Sciences Laboratory, Southern Illinois University, Carbondale*

---

*A greenhouse soil moisture control system for imposing stress levels is described. Moisture stress in this system results from opposing tensions between a moisture source and a vacuum pump and evapotranspiration. Tree Planters' Notes 37(1):2732; 1986*

---

In greenhouse experiments investigating competition among plant genotypes, plants are generally exposed to different levels of nutrients and allelopathic phytochemicals. Because nutrient availability and the effects of phytotoxins depend on the availability of soil water, control of soil water or moisture stress is imperative. This paper describes a tension lysimeter system designed to maintain two predetermined levels of negative pressure on a soil supporting a large number of seedlings. In this system, soil moisture content is controlled by a balance between evapotranspiration and a vacuum imposed through a ceramic cup in the bottom of the soil profile and moisture moving in response to tension through another ceramic cup in the center of the soil profile. Buffer tanks are used to maintain static tension and to minimize vacuum surges. The system insures drainage in the bottom of planting chambers and serves as a supplementary watering system.

As tested, the system supplied between 45 and 75 percent of total

water requirements needed to maintain -0.05 and -0.01 megaPascals (0.5 and 0.1 bars, respectively) soil moisture stress levels. Modifications to decrease supplementary watering can easily be made and are described. The stress levels can be changed as needed.

## Description of the System

Tension lysimeters rely on a moisture gradient for movement of water through the soil profile. The moisture gradient in this system results from opposing tensions between a moisture source and an imposed vacuum and evapotranspiration.

The system consists of a series of 32 experimental chambers in a greenhouse with partial environmental control (fig. 1). Each chamber measures 61 by 61 by 61 centimeters (outside dimension) constructed with 1.9-centimeter-thick plywood; it has rabbeted, caulked, and cross-screwed joints, and is painted on the inside with a roofing compound to prevent leakage (fig. 2). The floor of each chamber is recessed 1 centimeter into the sides and sloped 2.54 centimeters to minimize stagnation in the bottom of the box. The chambers are placed on 7.6- by 8.9-centimeter frames that are 1.3 centimeters higher on the side perpendicular to the 4 percent slope of the chamber floor; the result is that one corner of each chamber may serve as a point of moisture accumulation, although accumulation

would not be expected at these soil water contents except during wetting-in.

A standard 1.3-centimeter CPVC (chlorinated polyvinyl chloride) male pipe adaptor is used as a bulkhead union in the lower corner of each chamber; a 2.23-centimeter-outside diameter (o.d.) ceramic cup (0.1 megaPascal, standard flow, Soil Moisture Equipment Corp. No. 655X1-BIM1; 1 megaPascal = 10 bars) is attached to the inside and is closed with a rubber stopper on the outside. One end of a length of plastic laboratory tubing (Nalgene) (0.64 centimeter o.d. by 0.8-centimeter wall thickness) is inserted through the rubber stopper with the other end of the tubing connected to a 1-liter drainage bottle placed horizontally next to the base of each chamber; a second tube in this bottle is connected to a vacuum manifold. The vacuum creates a negative pressure in each bottle. This vacuum controls the soil moisture tension in each corresponding chamber (fig. 2).

The negative head pressure in the bottle is also used to control the watering system. A third tube connects each horizontal bottle with a water-filled bottle hanging upside down over each chamber; the vacuum head pressure tube in the hanging bottle must be above the fluid level of the water supply. Another tube from each hanging bottle is connected to a rubber stopper in a 46-centimeter-long, 3.8-centimeter-o.d., schedule 40



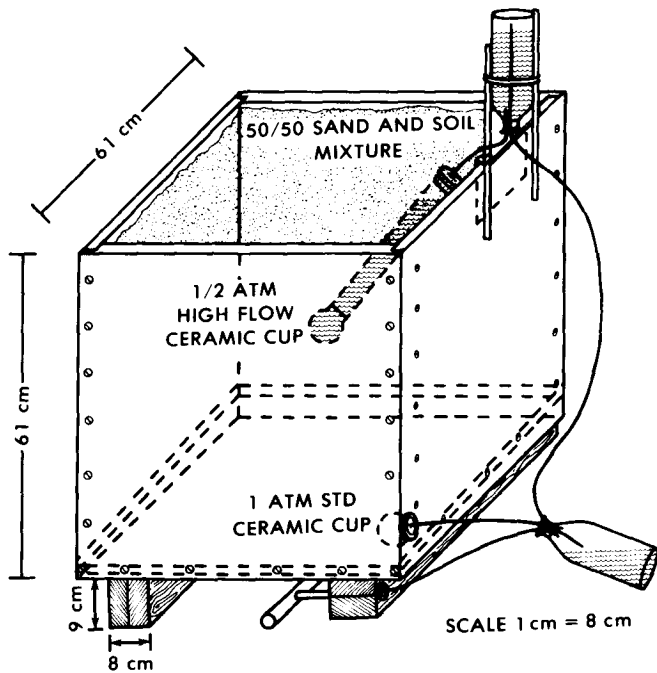

Figure 2—Diagram of experimental chamber with moisture control system.

The desired moisture stress is created by means of a rotary vacuum pump. We used a Surge Alamo Model 20 (566 liters per minute, 20 cubic feet per minute), which is commonly used by the dairy industry. In our system two stress levels were imposed, -0.05 and -0.01 megaPascals. The vacuum pressure levels are regulated by electrical vacuum controllers attached to buffer tanks; both vacuum controllers are 24-volt diaphragm microswitches (fig. 3). The purpose of the buffer tanks is to create a large enough vacuum reservoir to keep a static tension on the moisture system with a minimum of vacuum surges. The high

stress-high vacuum level results from a direct connection between a 5678-liter (1600-gallon) tank (approved by the American Society of Mechanical Engineers, or ASME) and the vacuum pump. The diaphragm microswitch attached to this tank normally remains open and is activated by a drop in vacuum in the tank. The low stress-low vacuum level is maintained by a second-stage 24-volt controller which regulates an in-line solenoid valve between the first- and second-stage buffer tanks. The switch normally remains closed. The second-stage tank has a 1892-liter (500-gallon) capacity and is also approved by the ASME (fig. 2).

Each buffer tank is attached to a PVC feeder line [inside diameter (i.d.) 1.7 centimeters]; feeder lines are in turn attached to CPVC manifolds (i.d., 1.2 centimeters) distributing the vacuum to experimental chambers. A third tank, in-line between the first-stage buffer tank and the vacuum pump, forms a condensate trap to prevent moisture from entering the pump (fig 2).

The soil used to fill the chambers was a uniform 1 to 1 mixture (by volume) of silty clay loam and medium-textured river sand. The sand was used to reduce the moisture gradient in the soil profile. Before the chambers were filled with the soil mix, approximately 0.7 kilogram of fine silica was placed around the small ceramic cups in the bottom of each chamber. The silica maintains continuity of capillary action between the soil and the ceramic cups. The soil in the chambers was watered-in from above over a 1-week period until field capacity was attained.

The effectiveness of the moisture control system was evaluated by weighing the soil-filled chambers biweekly. At the beginning of the experiment each chamber contained 256 kilograms of soil mix at 16 percent moisture content (on a dry-weight basis). Changes in chamber weight were attributed to soil moisture content changes and seedling growth. Because total seedling weight per chamber after one season's growth was negligible relative to the weight of the soil,

Electrical control panel for soil moisture stress chambers

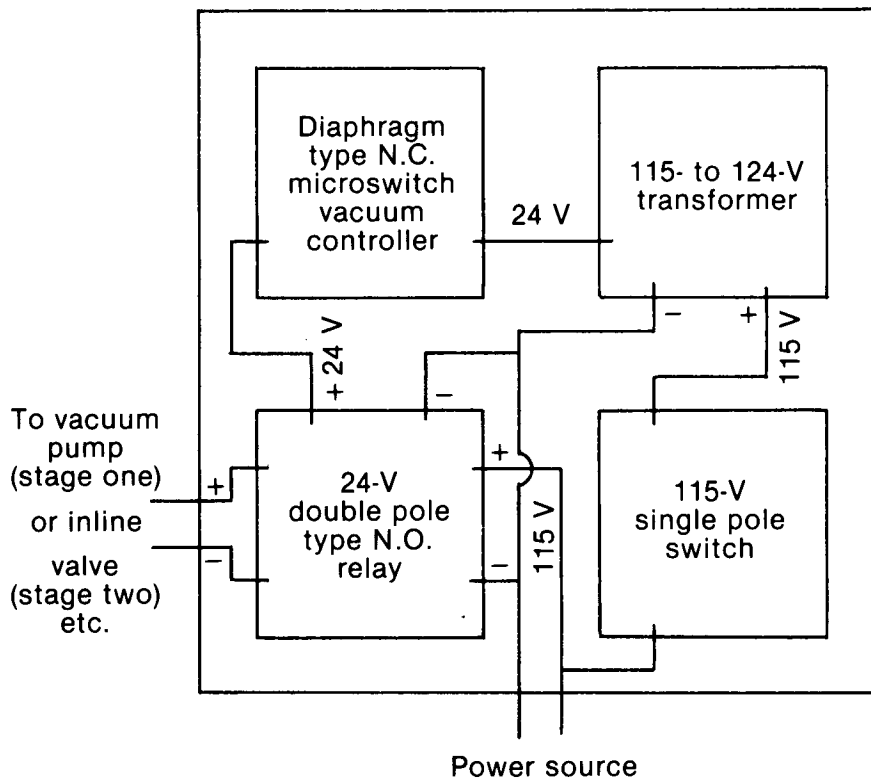

Figure 3—Electrical control panel for soil moisture stress chambers.

all weight changes were attributed to moisture content.

A steel cradle for lifting, moving, and weighing the soil-filled chambers was built with 5.0-centimeter-o.d. square steel tubing with 3.176-millimeter wall thickness; within the cradle a steel yoke supports two chain harnesses that can be attached to the chamber (fig. 4). The chambers are weighed by attaching an electronic transducer load cell (W. C. Dillon and Co.

Model Z, 454-kilogram capacity,  $\pm$  0.23-kilogram accuracy) between the yoke and the cradle.

**Performance of the System**

The main objective of this system was to maintain differences between two soil moisture stress treatments. This was done by applying -0.01 and -0.05 megaPascal of vacuum tension to the soils in the low-stress and high-stress treatment chambers, respec-

tively. The chambers contained black walnut seedling planted as germinating seed in April and grown for 20 weeks through August 1983. Measurements began approximately 1 month after planting.

Stress levels resulted in average total evapotranspirational water losses of 37.1 liters per chamber in the -0.01 megaPascal treatments and 13.5 liters per chamber in the -0.05 megaPascal treatments for the 4-month measurement period with 30 black walnut seedlings per chamber. Because the low-stress treatment also resulted in substantially faster growth (seedlings growing in the low-stress treatment were 48 centimeters in total height and 13 grams dry weight after 20 weeks versus 36 centimeters in height and 7 grams dry weight in the high-stress treatment), the three-fold difference in water loss also reflects greater transpiration rates on the part of the larger seedlings.

Analysis of variance of percentage of soil moisture (dry-weight basis) disclosed statistically significant differences between the two moisture stress regimes for all measurement periods (table 1). Although the differences in percentage of soil moisture declined until June 28, the minimal difference in soil moisture content between the two moisture regimes at this time (0.58 percent) is within the expectations of a sandy loam soil at these stress levels (1). In a sample of noncompacted soil subjected to the pres-

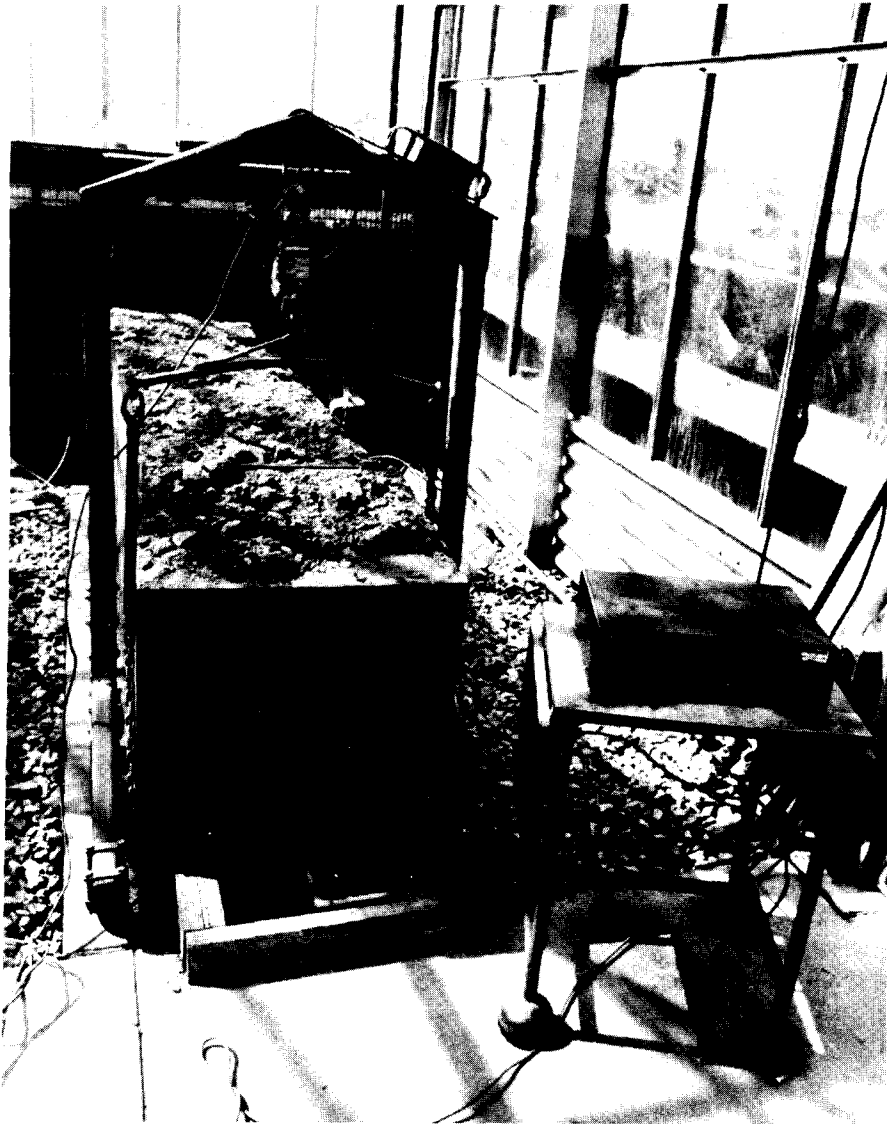

**Figure 4**—Cradle, yoke, and harness used to lift, move, and weigh chambers. Digital read-out is pictured to the right of the chamber.

sure plate extraction method, the difference in moisture content between soil under -0.05 megaPascal of tension and that at -0.01 megaPascal was 1.7 per-

cent (see chart at right), a value comparable to the differences measured at the beginning of the study.

Negative pressures (MPa)	Soil moisture (%)
-0.01	15.87
- .03	14.56
- .05	14.18
- .10	14.06
- .50	4.47
- 1.00	4.35
-1.50	3.80

In addition, standard deviations around average soil moisture contents per chamber indicate that moisture distribution between chambers was relatively uniform (table 1). Increases in the difference in moisture content between the two stress regimes beyond June 28 are the result of supplementary watering of low-stress treatment chambers to alleviate unexpectedly high evapotranspiration rates encountered at this time. The high evapotranspiration rates resulted from a combination of larger seedlings transpiring greater quantities of water and record high temperatures in the summer of 1983.

The soil in the chambers developed a dry hard crust approximately 2.5 centimeters thick; beneath this surface crust, soil moisture was apparently uniformly distributed. No moisture had stagnated in the chamber bottoms. Because the walnut seedlings were removed from the chambers with intact roots, there was ample opportunity to observe the direction of root growth. There was no indication of root growth toward the center of the chamber (the location of the ceramic cup that was the

**Table 1**—Average percentage of soil moisture per chamber and standard deviation (SD), on a dry-weight basis, for six measurement periods

Stress level	Percentage soil moisture (ave. ± SD)					
	May 17	June 2	June 14	June 28	July 26	Aug 9
Low (−0.01 MPa)	15.54 ± 0.47	12.90 ± 0.80	10.87 ± 0.91	9.13 ± 0.70	7.55 ± 0.75	9.23 ± 0.72
High (−0.05 MPa)	13.96 ± 0.35	11.80 ± 0.64	10.10 ± 0.74	8.55 ± 0.73	6.65 ± 0.84	6.23 ± 0.74
Differences	1.58	1.10	0.76	0.58	0.90	2.91

water source); thus, we assumed that the moisture permeated the soil uniformly by means of capillary action. Similarly, there was no evidence of faster growth of walnut seedlings in the center of the chambers in contrast to seedlings located in other parts of the chambers.

As stated earlier, the moisture control system provided an average of 37.1 and 13.5 liters per chamber of water in the low-and high-moisture-stress treatments, respectively. Although this was adequate to maintain moisture stress differences between the two treatments, it is evident from table 1 that, due to evapotranspiration, absolute stress levels exceeded the -0.01 and -0.05-megaPascal values imposed by the vacuum system. In order to maintain those absolute stress levels, we would have needed to add a total of 13.6 and

16.4 liters per chamber of water to each low-and high-stress chamber over the 20-week experimental period. The moisture control system would have provided 73 and 45 percent of the total water requirement of the low- and high-stress treatments, respectively, if the system had been designed to maintain -0.01 and -0.05 megaPascal of absolute moisture stress.

**Conclusion and Recommendations**

In summary, the moisture control system described here maintained soil moisture differences between the two stress treatments and provided drainage to prevent stagnation in the chambers. The system also supplied between 73 and 45 percent of the watering requirements; the total watering requirement could probably be provided by a) increasing the size of the water supply bottles and b) provid-

ing another ceramic cup in each soil profile. This would increase the efficiency of the system, which depends on the size and number of ceramic cups providing water as well as soil texture, volume, and rate of evapotranspiration. Such systems may be of interest to other researchers dealing with greenhouse experiments in which soil environment must be controlled.

**References**

1. Rode, A.A. Theory of soil moisture. In: Moisture properties of soils and movement of soil moisture, Vol. 1. *Gidrometeorologicheskoe Izdatel'stvo*. [Translated from Russian]. TT 6850441. Jerusalem: Israel Program for Scientific Translations, for the U.S. Department of Agriculture and the National Science Foundation; 1969. 560 p.