

Building a Hand-Held Dispenser for Top-Dressing Containers

R. Kasten Dumroese, David L. Wenny, and Thomas Gisselberg

Research associate and professor/manager of the Forest Research Nursery, University of Idaho, Department of Forest Resources, Moscow, ID; and former farm mechanic, University of Idaho, Department of Plant, Soil, and Entomological Sciences, Moscow, ID

A "gritter," a hand-held dispenser for top-dressing containers with perlite, vermiculite, or grit, can be built according to simple plans. *Tree Planters' Notes* 42(2):56-61; 1991.

Growers of container seedlings routinely cover seed with a layer of perlite, vermiculite, or grit to hold the seed in contact with moist medium, to prevent the seed from splashing out of the container during irrigation, and to reduce growth of algae and moss. At the University of Idaho, we have designed a hand-held dispenser (fig. 1) for top-dressing our containers that gives us an easily applied, uniform covering. The device, which we call a "gritter," is the last step in our sowing line. We use it to top-dress about 120,000 cells per day with white grit (fig. 2).

General Description and Materials

The model was designed to top-dress pine cells and is therefore 12 inches wide; gritters to cover other widths can also be built. The operator uses the gritter to scoop material from a container and then spread it over the block. The gritter is positioned on the block with the stout rubber strip resting on the block. When the handle is squeezed, the piano hinge along the bot-

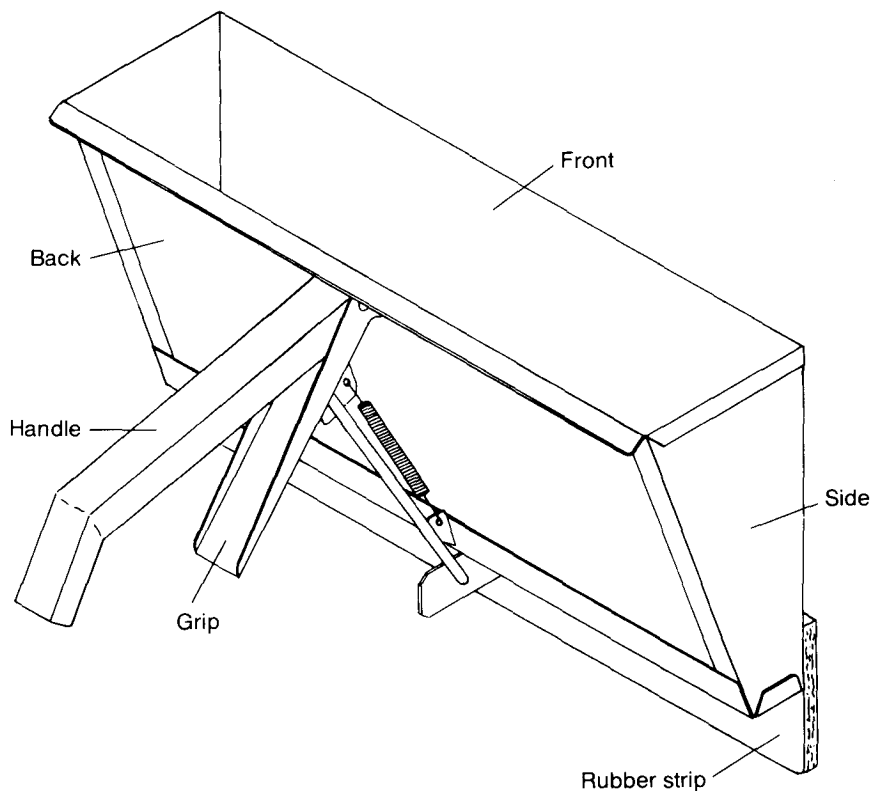

Figure 1-Isometric drawing of the gritter.

tom opens, releasing the material. Pulling the gritter along the top of the block while squeezing the handle allows the rubber strip to spread the falling grit uniformly across the block.

Making the gritter requires the following 4 pieces of 16-gauge sheet metal:

- ?? one 7¹/₂- by 18¹/₈-inch piece (front and sides of the bin; fig. 3)
- ?? one 7¹/₂- by 12¹/₈-inch piece (back of the bin)
- ?? one 2¹/₄- by 4¹/₄-inch piece (handle) plus a similar small piece to make three small tabs (fig. 4).



Figure 2—Using the gritter to dispense white gravel on containers.

plus the following items:

- ?? 8 inches of $\frac{3}{4}$ -inch square steel tubing
- ?? 6 inches of $\frac{1}{4}$ -inch-diameter steel rod
- ?? one 2-inch by $12\frac{5}{8}$ -inch-long piano hinge
- ?? one 2 by 12-inch piece of $\frac{5}{16}$ -inch-thick rubber, from a piece of old conveyor belt or

- truck mudflap or other suitable source
- ?? five $\frac{3}{16}$ -inch steel pop rivets with large flanges
- ?? one 2-inch helical tension spring

Constructing the Bin

To make the front and side piece of the bin, hem the largest piece of

sheet metal $\frac{1}{4}$ inch along its long ($18\frac{1}{8}$ -inch) side. Trim off the excess metal, hem and bend as shown in figure 3.

To make the back, hem the next large piece of sheet metal $\frac{1}{4}$ inch on all four sides and fold the top back across the top at about a 90° angle.

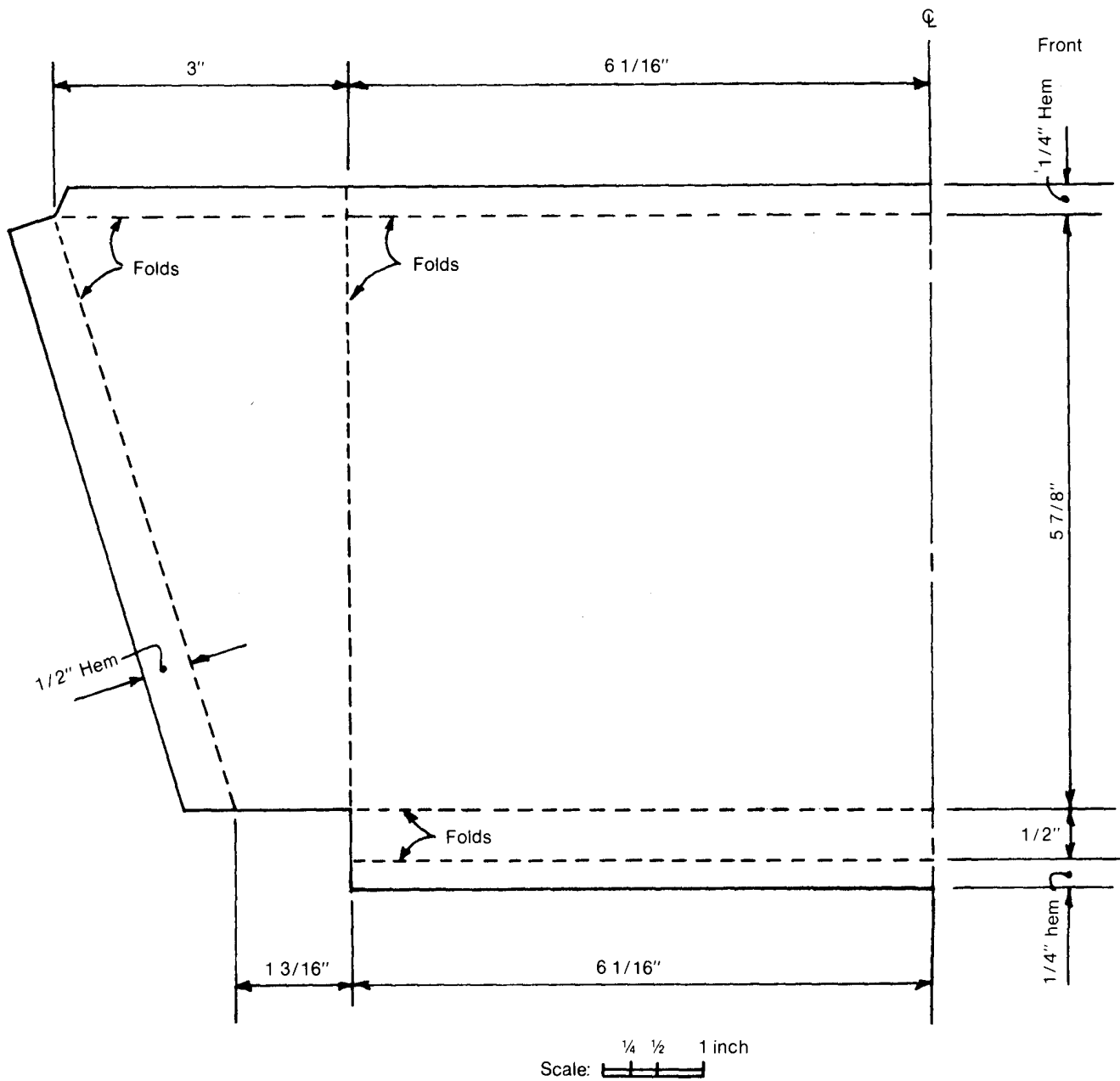

Figure 3—Half template for cutting the 16-gauge sheet metal for the front and sides of the gritter.

Bend the outer metal tabs of the piano hinge over about $\frac{1}{4}$ inch. Weld the hinge onto the base of the smaller piece of sheet metal, and fill the holes in the hinge with the welder. Attach the rubber to the larger piece of sheet metal with pop rivets, with about $1\frac{3}{8}$ -inch of the rubber extending below the bottom of the larger piece of sheet metal (fig. 5). Then weld together the two pieces of sheet metal.

Constructing the Handle

Make the trigger release from the third piece of 16-gauge sheet metal (figs. 4-6). Cut three tabs from the last piece of sheet metal and weld them to the trigger release or piano hinge (fig. 5). Note that the hinge tab, a hemmed piece of metal, is offset below the trigger release. Cut the $\frac{3}{4}$ -inch steel tubing into two pieces with dimensions as indicated in figure 5 and weld together. Then weld the handle onto the back of the bin as shown in figs. 5 and 6. Connect the trigger release to the handle with an inch-long piece of steel rod. Connect the trigger release tab to the piano hinge tab with a steel rod as indicated in fig. 5. Attach the spring between the trigger release tab and the upper piano hinge tab.

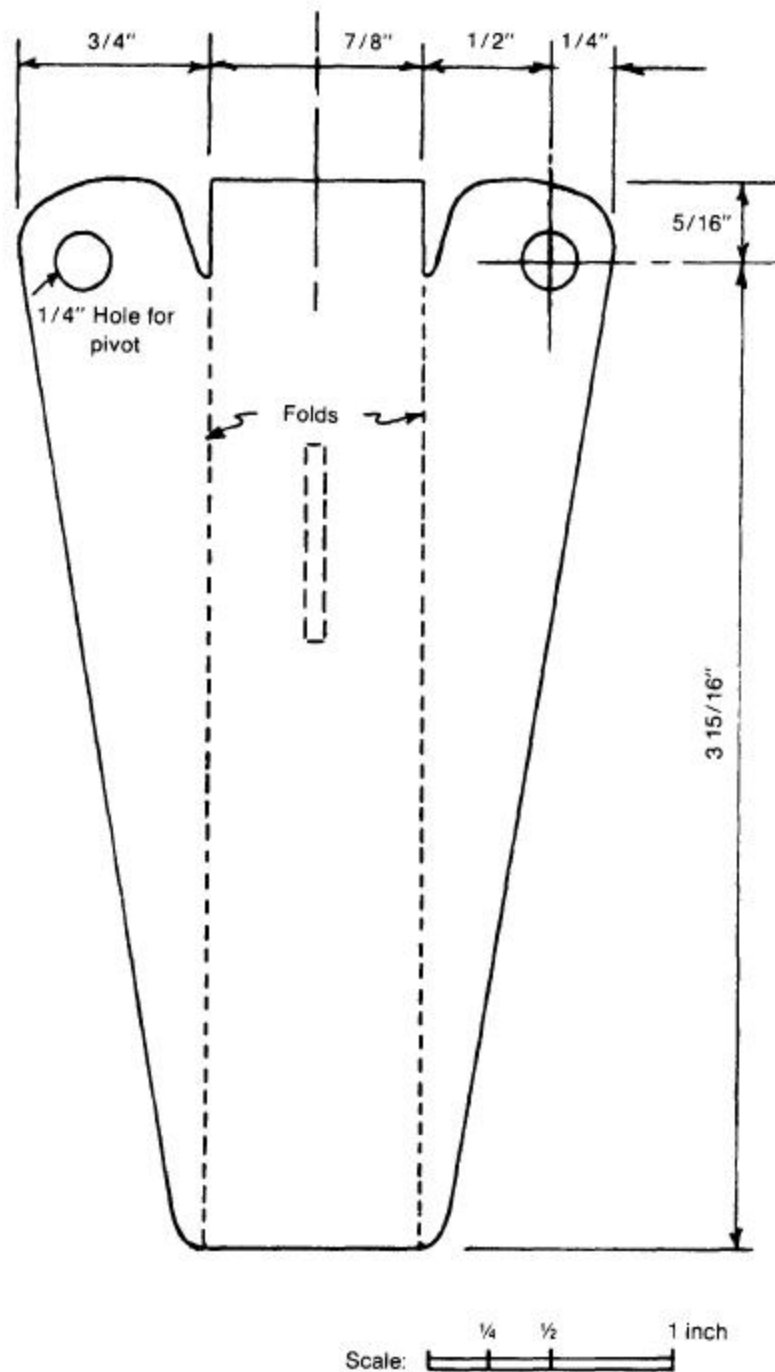

Figure 4—Template for cutting the 16-gauge sheet metal for the handle of the gritter.

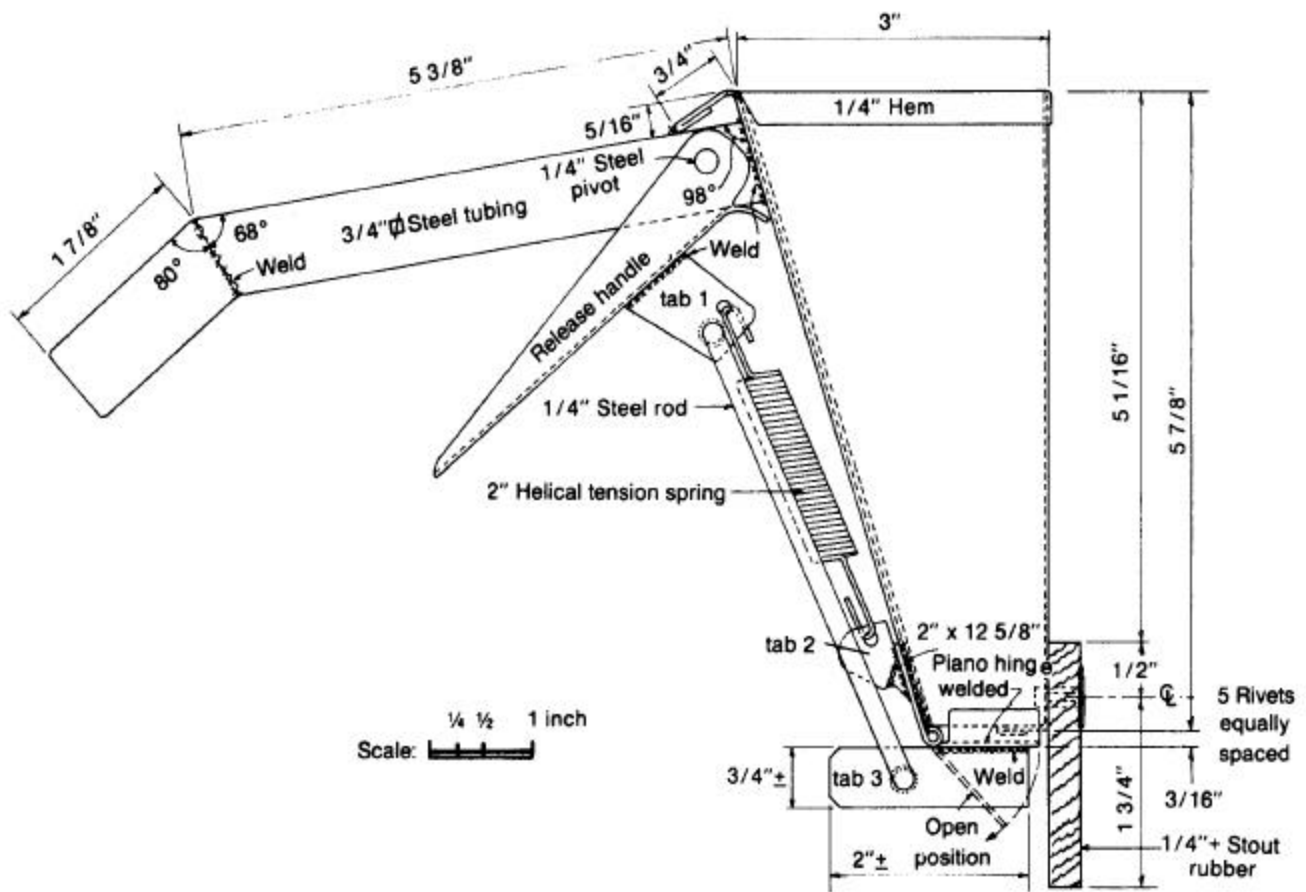

Figure 5—Side elevation of the gritter.

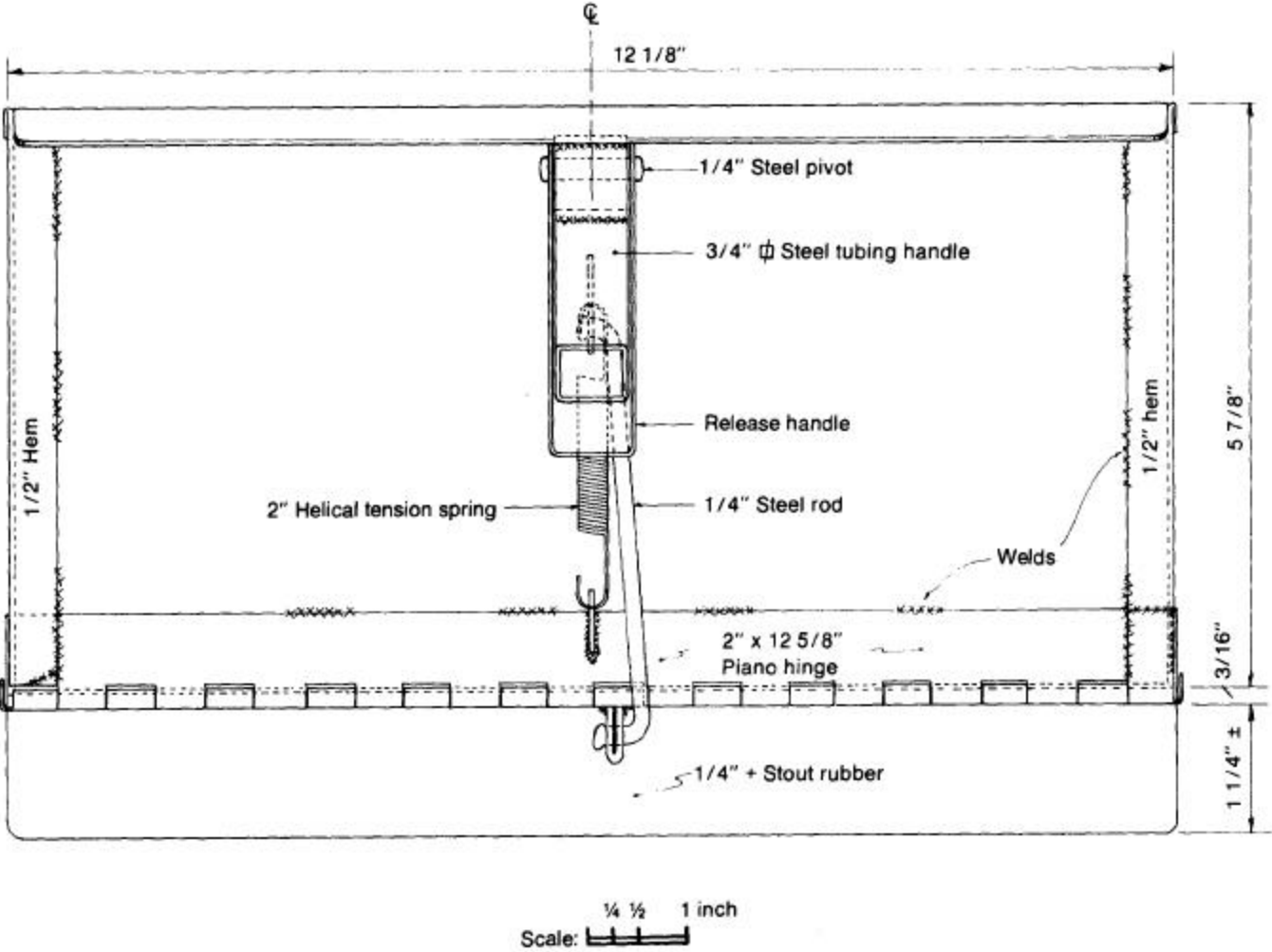

Figure 6—Rear elevation of the gritter.