

Treatment of Container Seedlings in the Nursery Against Large Pine Weevil

Leo Tervo, Juhani Kangas, Martti Kuikka, and Riitta Sarantila

Forest engineer, Finnish Forest Research Institute, Suonenjoki Research Station, Suonenjoki, Finland; professor, Kuopio Regional Institute of Occupational Health, Kuopio, Finland; technician, Finnish Forest Research Institute; and scientist, Kuopio Regional Institute of Occupational Health

An experimental tunnel sprayer for treating seedlings with insecticides against the large pine weevil-Hylobius abietis (L.) was built and tested at the Suonenjoki Research Station and Nursery. The goal was to achieve an efficient and effective system for distributing insecticide that is also safe for the operator. Permethrin was distributed over about 80% of the seedling shoot when the inventory method was used for determination, but over 100% according to a visual check. Treating 1,000 seedlings cost \$1.40 for labor and \$4.21 for total costs. Treating seedlings was more efficient and economical at the nursery than at the planting site. The workers' exposure to permethrin was far below the 5-mg/m³ limit in Finland. The measured contamination of the hands and protective clothing confirmed that the correct use of personal protective equipment in pesticide work is necessary. Tree Planters' Notes 45(1):5-9; 1994.

Several methods are used in combating the large pine weevil, *Hylobius abietis* (L.): either mechanical plant guards or chemical treatment of seedlings with insecticide. It is common to treat bareroot seedlings in the field by having the planter dip the seedlings individually into the chemical solution, shoots first, up to their root collars. This is considered to be an effective protective method. The treatment of container seedlings in the field before planting is not common. However, in nurseries, mass treatment using tunnel equipment or tractor sprayers constructed for this purpose is becoming more common. In some nurseries, both bareroot and container seedlings are sprayed at the nursery.

Since the banning of lindane, synthetic pyrethroids have been used increasingly in the protection of seedlings against pine weevil. Permethrin is a common pyrethroid-based product for this purpose. Permethrin is absorbed into the human system through the alimentary tract and to a lesser extent through the respiratory tract. Absorption through the skin is regarded as insignificant (Elliot et al. 1976). Permethrin has caused skin and eye irritation to operators who have been exposed to it (Kolmodin-Hedman et al. 1982a).

We hypothesized it would be safer and possibly cheaper to treat seedlings in the nursery and so decided to build and test a machine for this purpose. The equipment used in the study was built at the Suonenjoki Research Station and Nursery. The aim was to achieve an effective system (work productivity and evenness of insecticide distribution) that is capable of treating different container seedlings against pine weevil (figure 1). The working principle of the unit is shown and described in figure 2.

Materials and Methods

Research equipment. The tunnel was 2.8 m long and 1.2 m in maximum width; it weighed 220 kg. The unit was built on wheels to improve mobility. The capacity of the spray tank was about 300 dm³ and the spray nozzles were of fan type. The unit worked from a 380-V power supply. The seedlings were treated by 2 workers, one to feed boxes into the machine and the other to take them off the conveyor and placing them on the ground or onto a pallet. A seedling box was placed on the conveyor in a normal position. Clamps on both sides of the box held it in place during spraying. Inside the tunnel, the box was tilted to a near vertical position (about 75°) to reduce the amount of pesticide solution flowing onto the growth medium (peat), that is, when tilted, the pesticide drips off the seedling by force of gravity onto the floor of the unit. The spraying took place in an enclosed space.

The unit was used to treat 1-year-old container pine seedlings. The pesticide used was a water-soluble spray powder, F-permethrin (active ingredient: permethrin, cis/trans isomeric ratio 25:75 and LDS₅₀-value of about 6,000). The concentration of the spray solution was 2% (that is, 0.5% active ingredient).

Pesticide distribution and coverage of seedlings. The pesticide distribution and coverage of the seedlings was determined using a herbicide coloring agent in water. This solution was sprayed onto seedlings, around which Kromekote® paper had been wrapped at a height of 50 mm from the surface of the growing

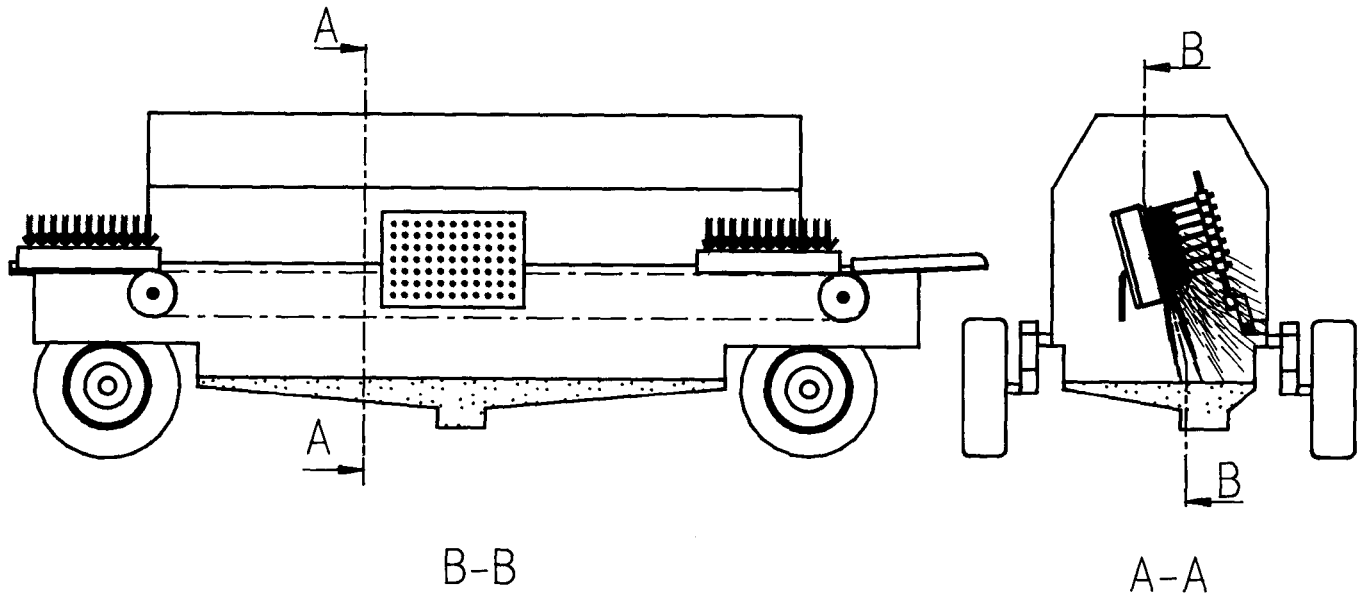

Figure 1—Tunnel sprayer, built at the Suonenjoki Research Station and Nursery, for protection against large pine weevil.

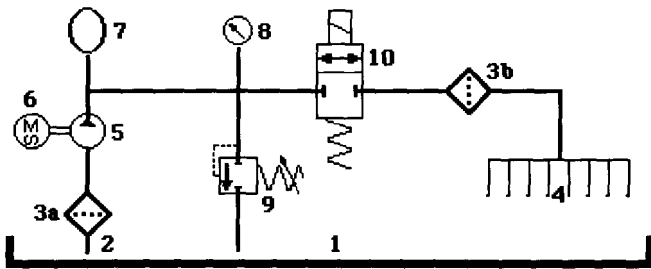

Figure 2—The working principle of the unit. The spray solution was in the spray tank (1) from where the pump (5) sucked the solution through a suction filter (3a) into the tube system (2). From there the solution went under pressure through a filter (3b) and was distributed to the spray nozzles (4), type Unijet 6503. As the seedling box passed the limit switch it pressed a limit switch down, thus opening the magnetic valve (10) allowing the solution to flow to the nozzles. After the seedling box passed the limit switch the magnetic valve closed and the flow to the nozzles stopped. The pressure regulator valve (9) was adjusted to the required pressure, which could be followed on the pressure gauge (8). The excess solution flowed back into the spray tank. The power of the pump (5) was 2.2 kW and its capacity was 70 dm³/min. The pump was fitted with a pressure chamber (7) that evened out the flow of the liquid.

medium (Higgins 1967). The coverage of 1-mm² grids on the 2mm-wide vertically placed strips of Kromekote paper was tallied according to classes 100%, 75%, 50%, 25% and 0% from four directions.

The seedling types in the study were Vapo® container (5 cm x 5 cm and height 8 cm) and Ecopot® (Ps-508, diameter 4.6 cm and height 7.5 cm

and Ps-608, diameter 5.6 cm and height 7.5 cm) seedlings. The Vapo seedlings are in more clearly defined rows than the other types of seedling. The work productivity study material consisted of about 140,000 seedlings, equivalent to about 1,300 seedling boxes.

Operators' exposure to permethrin. Each worker wore protective garments (MIX 50/50/cotton/polyamide), peaked cap, face shield, rubber boots (Nokia), and a polyethylene apron. When preparing the spray suspension the worker used neoprene gloves (MULTITOP, France) and a respirator with a combination filter (KEMIRA A1). The workers wore cotton T-shirts, cotton trousers and shorts, and cotton socks under their protective garments.

The exposure of the workers was evaluated by industrial hygienic measurements and biological monitoring. The workers' exposure to permethrin via lungs was estimated from air samples taken with portable pumps on membrane filters in the breathing zone of the workers. Stationary air samples were installed near the application equipment about 1.5 m above ground level. Sampling times were equivalent to the application times. The contamination of the clothing and skin was estimated by patch tests. Exposure through the hands was measured from the cotton gloves worn under the protective gloves (Davis 1980).

Urine samples for biological monitoring were taken after each work day for the determination of metabolites of permethrin and for estimation of the workers' exposure to pesticide from the concentration of metabolites in urine. Filter, patch, and urine samples were

analyzed in a gas chromatograph (HP 5880) equipped with a capillary column (HPI) and EC detector (Kolmodin-Hedman et al. 1982b).

The workers underwent a medical health examination before and after application work. Special care was taken to note possible symptoms that might have occurred during the work.

Results

Spray consumption and evenness. During the compilation of the study material, the spray consumption varied from 0.18 to 0.28 dm³ per box sprayed according to the speed of the conveyor.

There was no significant difference in the distribution of pesticide between the different container types (Vapo, Ps-508, Ps-608), although the seedling growth density was greater in type Ps-508. According to the tally of the Kromekote strips (size 30 mm x 30 mm) that had been placed horizontally on the surface of the growing medium, the spray coverage for the Ps-508 seedlings was 90%; for the Ps608, 97%; and for the Vapo seedlings, 98% (figure 3).

The test unit did not function fully in the desired way. There were shortcomings—for instance, in the box-gripping mechanism on the conveyor, which holds the box in the required position, and in the mixing of the spray agent. The concentration of permethrin in the samples taken from the spray tank varied widely, indicating that the tank mixing was apparently not sufficiently effective. The reservoir collecting the run-off spray agent was separate from the main spray tank during the test to determine the evenness of distribution of spray on the seedlings. Separating the reservoir from the main tank improved the mixing of the agent.

Spraying work productivity. A 2-person team treated the seedlings. One operator fed the boxes into the machine and the other took the treated boxes off the conveyor and placed them back onto the ground. In a time study of the work, in which productivity and work time distribution were measured, the distribution of the tunnel sprayer operating time was as follows:

Actual spraying work	70.3%
Transporting sprayer & conveyors	20.2%
Adjusting sprayer	0.4%
Adding pesticide and transferring	
from run-off reservoir	8.4%
Repairing roller conveyor	0.7%
	<hr/>
	100.0%

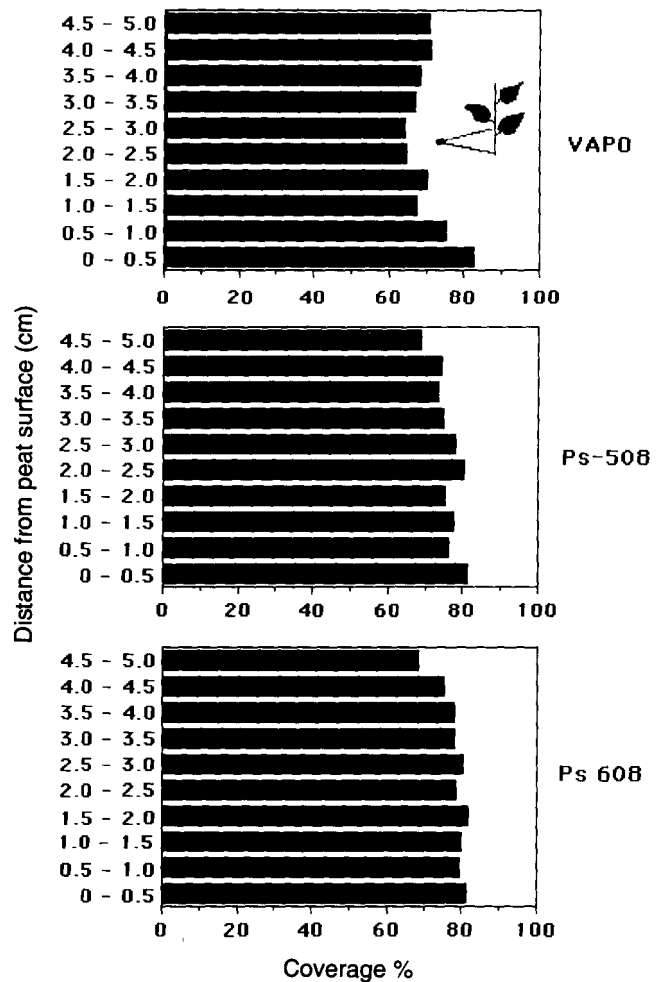

Figure 3—The distribution of colored water on the stem of a seedling according to the Kromekote strip tally.

The spraying work output was 4 boxes per minute. According to the operators' work time distribution, operator B had to wait part of the time (table 1). Feeding the box to the machine took 34.9% of operator A's time. This may also have included some waiting. The speed of the conveyor was 8.4 m/min during the test. The speed of the conveyor is adjustable between 5.4 and 32.6 m/min.

Costs. The annual operating time of the equipment used in the calculation was 120 hours. The operating time corresponds to the treatment of about 3 million seedlings. The hourly operator costs used were \$10.50. The team comprised two operators.

On the basis of the aforementioned values, the tunnel sprayer costs were \$11/hour. The cost of the pesticide was \$70.20/kg. The consumption of pesticide solution was 0.18 to 0.28 dm³ per box, depending on

Table 1-Operators' working time without interruptions

Operation	Operator A	Operator B
Go to box	23.2%	28.3%
Take box	16.3%	25.4%
Carry box	25.6%	20.8%
Feed box into machine	34.9%	
Position box on ground		13.9%
Wait	-	11.6%

output. When using the average consumption of 0.2 dm³ of 2% solution in the calculations, the actual use of pesticide was 4 g/seedling box. The cost of pesticide was \$2.80/1,000 seedlings, when the box contained 100 seedlings. The output of spraying work used in the calculations was 4 boxes per minute. The total costs of the treatment were \$4.21/1,000 seedlings.

Workers' exposure to permethrin. The permethrin concentration in the air was low and varied between the detection limit up to 140 : g/m³. The highest concentrations were measured in stationary samples during the dilution of powder formulation (table 2).

The patch tests revealed that the contamination of the clothes was 230 to 4,300 : /cm²/hr in the dilution work and 320 to 600 : g/cm³/hr in the treatment of seedlings and in maintenance work. In some cases, almost half of the amount of the pesticide on the protective clothing was found in the patches that were inside the clothes. Skin contamination was, however, estimated to be low. The urine concentrations of the metabolites of permethrin were in all cases below the detection limit of the method. This also proves that the workers' exposure during the application work was minimal.

The amount of permethrin in the cotton gloves was 0.06 to 2.00 mg. This proves that the hand protection was not complete, partly because the preparation of the application equipment was done without using protective gloves. The highest values of permethrin on

the cotton gloves were noted after this kind of work. The workers complained about irritation and itching on their faces during the work, but no specific exposure-related symptoms were found in the health examination after the work.

Discussion

Our findings are limited in that the prototype equipment was used during this study only. However, the knowledge and experience acquired show that the working principle of the sprayer is worth developing.

The effect of tilting the box to reduce the flow of pesticide to the growth medium could not be evaluated in this study. This would require a separate test comparing the spraying operation in horizontal and near-vertical boxes. Equipment to treat seedling boxes in the nursery beds using tractor-mounted sprayers are in use today. It would be appropriate to continue the study and compare the aforementioned alternatives.

The distribution of the spray agent on the surface of the shoot was approximately 80%, according to the inventory method that was used. According to a visual check, however, the seedlings were completely treated. It is possible that the use of Kromekote paper and colored water is not a completely reliable method for such small seedlings and such growth density. It would also be appropriate to conduct a feed test with pine weevil after treatment.

The cost of pesticide was \$2.80 and the cost of handling was \$1.40/1,000 seedlings. The treatment of seedlings in the nursery is generally more justifiable and is considerably more economical than treatment in open terrain. According to Tervo (1989) the cost of treatment per hectare was \$13.20 to 33.60 per 1,000 seedlings when carried out using a backpack sprayer after planting in open terrain. The equivalent cost of treatment in the nursery would be approximately \$4.20 per 1,000 seedlings. The treatment of bareroot seedlings against pine weevil, for instance using the sprayer with the recycling principle, should be studied more closely (Tervo et al. 1991).

The occupational exposure limit for permethrin in Finland is 5 mg/m³. According to the results of the occupational hygienic measurements, the exposure of the workers was far below this value. The concentrations of the metabolites of permethrin in the urine samples taken after the work shift were below 0.05 mg/ml. The measured contamination of the hands and protective clothing, however, proved that correct use of personal protective equipment in this work is necessary.

Table 2 – Air concentrations of permethrin in the breathing zone and at the stationary sampling points during the dilution of spraying solution and during the application of the seedlings

Object	Permethrin (: g/m ³)		
	Mean	Range	n
1. Worker A (personal sample)	5.3	0.4 --23.7	5
2. Worker B (personal sample)	2.2	0.4 -- 7.7	5
3. Dilution of spraying solution (stationary sample)	64.5	23.7-137.5	3
4. Feeding conveyor of the applicator (stationary sample)	< 0.5		3
5. On the side of the applicator (stationary sample)	< 0.5		3
6. Conveyor for applicated seedlings (stationary sample)	< 0.5		3

Some workers complained about irritation and itching on their faces during the work, but no specific symptoms that could be related to pesticide exposure were found in the health examination done after work. These kind of symptoms are reported to be typical for workers exposed to Synthetic pyrethroids (Kolmodin-Hedman et al. 1982a).

Powder-formulated pesticide was used in this study. There is a risk for elevated inhalation exposure during the dilution of the spraying solution liquid. We therefore recommended that workers use a respirator.

equipped with a filter against fine aerosols during the dilution of spraying solution. The use of suspension would decrease the exposure of workers (Metker et al. 1977).

The preparation and maintenance of the application equipment increased contamination of the gloves. When protective clothing gets wet from the spraying solution in this work, it seems that a considerable amount of pesticide penetrates the garment. It is therefore advisable to change the protective clothing after preparation work, and to take a shower if the contamination of the clothes is obvious.

The preparation and maintenance of the application equipment increased contamination of the gloves.

When protective clothing gets wet from the spraying solution in this work, it seems that a considerable amount of pesticide penetrates the garment. It is therefore advisable to change the protective clothing after preparation work, and to take a shower if the contamination of the clothes is obvious.

Literature Cited

- Davis JE. 1980. Minimizing occupational exposure to pesticides: Personal monitoring. *Residue Reviews* 75:33-50.
- Elliot M, Janes NE, Pulman DA, Gaughan LC, Unai T, Casida JE. 1976. Radiosynthesis and metabolism of rats of the isomer of the insecticide permethrin. *Journal of Agricultural and Food Chemistry* 24(2):270-276.
- Higgins A. 1967. Spread factors for technical malathion spray. *Journal of Economic Entomology* 60:280-281.
- Kolmodin-Hedman B, Swensson Å, Åkerblom M. 1982a. Occupational exposure to some synthetic pyrethroids (permethrin and fenvalerate). *Archives of Toxicology* 50:27-33.
- Kolmodin-Hedman B, Edling C, Fischer T, Rand G, Åkerblom M. 1982b. Undersökning av nya applikationsmetoder för snytbagg bekämpning med pyretroider. *Läkartidningen* 79(21):2105-2107.
- Metker LW, Angerhofer RA, Pope CR, Swentzel KC. 1977. Toxicology: Evaluation of 3-(phenoxyphenyl)methyl(+)-cis, trans-3-(2,2-dichloroethenyl)-2,2-dimethylcyclopropanecarboxylate (permethrin). Rep. 75-51-0837-78. U.S. Army Environmental Hygiene Agency.
- Tervo L. 1989. Ekbacken-räsku tukkimiehentäin torjuntaan met sänviljelyaloilla. [Abstract: The Eckbacken backpack sprayer used for spraying individual Scots pine seedlings in plantation against *Hylobius abietis*.] *Metsäntutkimuslaitoksetiedonantoja* 338.
- Tervo L, Kangas J, Kurtio P. 1991. A nursery sprayer with the recycling principle. *Scandinavian Journal of Forest Research* 6:259-270.